

BEYOND
INNOVATION,
A CERTAINTY
OVER TIME

3-ROW Articulated Electrostatic Sprayer

PHANTOM "NewPortTrio"

Productivity, Versatility, Maneuverability

NEW



ISO
BUS

4.0



 **ELECTROSTATIC**[®]
AGRO SPRAY SYSTEM

...pioneers since 1981

1988 - FIRST IN THE WORLD to create a 3-row sprayer (Whirlwind Turbo 3) for vine growing - EIMA TECHNICAL INNOVATION award-winning

TODAY - LEADER with the most COMPLETE and PROVEN range of over the row sprayers for very high productivity treatments on vineyards, berries, etc.

MAIN CONSTRUCTION FEATURES

- **Heavy duty steel** frames with “Duplex” treatment complete with support feet for storage
- **Transmission** with oil bath gear box and device for fan disengaging
- **Tank trailer capacities:** 600 – 1000 – 1500 l with large reclining platform for tank inspection – adjustable drawbar in length (3 positions to choose from) – axles and wheels (6 holes) adjustable in width and height
- **Over-the-row structure** with PATENTED kinematics:
 1. Operates indifferently on inter-rows from 1.60 MT to 3.10 MT with hidraulic device - On demand: “touch” electronic management from the driving seat
 2. Reduced turning radius – high maneuverability
 3. Minimum space requirements for storage, transport and road transfers (1,60 MT WIDTH - 2,50 MT HEIGHT)
- **Flexible air duct** equipped with PVC coated polyester tube which provides excellent resistance to chemical and atmospheric agents combined with mechanical resistance suitable for frequent handling.
- **Self-priming centrifugal pump** entirely in stainless steel with SSM mechanical seals (Special Seal Martignani) resistant to highly concentrated chemical mixtures
- **Newly designed centrifugal fan** with double outlet and front air intake which prevents the suction of the chemical mixture - possibility of excluding the air on the two external descents.
- **Precision metering valves** with graduated scale in stainless steel for each spray head

ACCESSORIES ON REQUEST:

- Automatic control and monitoring of spraying with 4.0, ISOBUS or PRECISION FARMING systems
- “Mother Regulation” road approval

TECHNICAL DATA

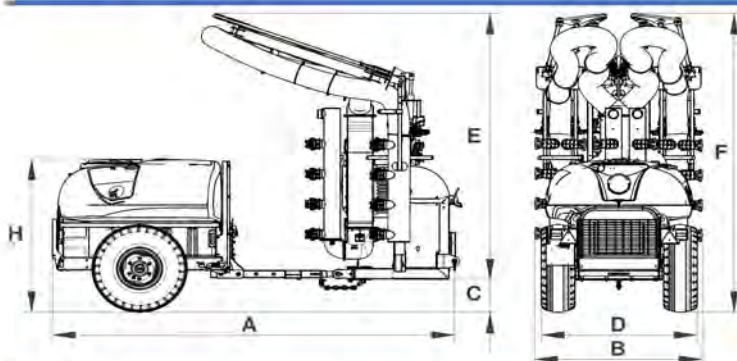

Description	TRIO		
Capacity (lt)			
Tank	600	1000	1500
Circuit Rinsing Tank	100		
Hand Wash Tank	15		
Weight (kg)			
Empty mass	1150	1260	1300
Fully loaded mass	1850	2375	2915
Tires			
205/65 - 15 (1)	✓		
225/70 - 15 (2)	✓		
260/70 - 15.3 (3)		✓	✓
340/55 - 16 (4)		✓	✓
300/80 - 15.3 (5)			✓
Dimensions (mm)			
A	3750	3680	3870
B	1600		
E	2500		
D (1)	1000		
D (2)	1050		
D (3)		1330	1350
D (4)		1400	1430
D (5)			1410
H (1)	1300		
H (2)	1330		
H (3)		1460 - 1570	1640 - 1750
H (4)		1530 - 1640	1720 - 1830
H (5)			1720 - 1830
C (1)	260		
C (2)	290		
C (3)		260 - 370	260 - 370
C (4)		325 - 435	325 - 435
C (5)			325 - 435
F	E + C		
Mist Blower Specifications			
Tractor power required	62 kW (85 CV)		
Absorbed power by the sprayer	28 kW (38 CV)		
Pump flow rate (l/m)	180		
Operating pressure (bar)	1,5		
Fan air capacity (m3/h)	13500		
Air Speed (m/s)	70 m/s		

